

# AH474 / AH24474

## AUXILIARY HEATER

12 & 24 VOLT

### CONTENTS:

Heater • Mounting Brackets • Installation Kit • Instruction Sheet

### INSTALLATION KIT INCLUDES:

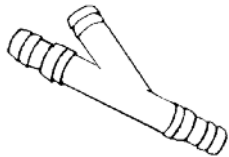

(2) Y Splicers

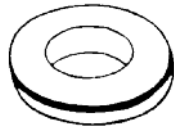

(2) Rubber Grommets



(8) Hose Clamps



(4) Mounting Screws



(1) 7.5A Inline Fuse

### INSTALLATION DIAGRAM:

Materials required to install this heater are available in the kit shown above. In addition you will need 5/8" heater hose and 14 GA wire.

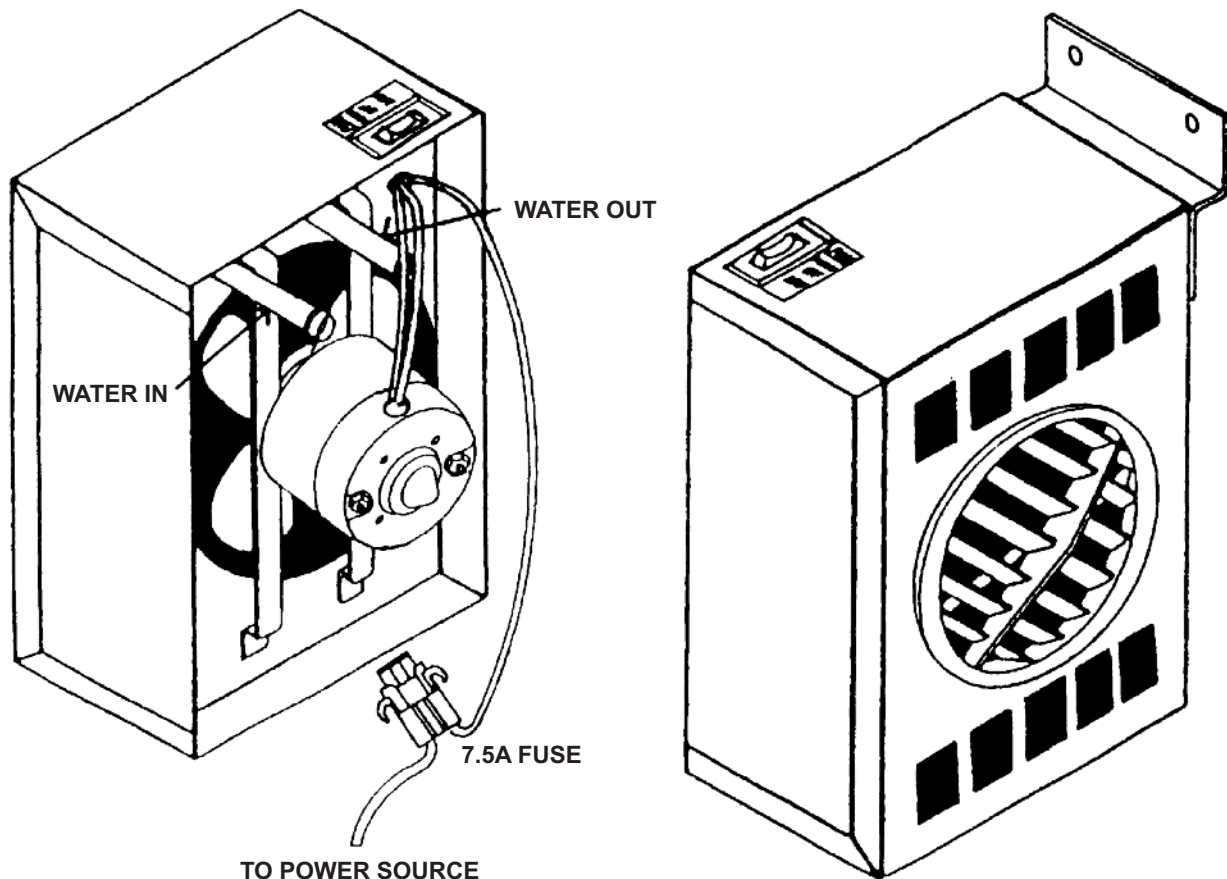

## **INSTALLATION INSTRUCTIONS:**

1. This versatile heater may be mounted vertically. Typical locations include floor, wall or under dash.
2. Route the heater hose to the engine compartment, using grommets through the fire wall, cut the existing hose, add and clamp the Y splicer then run the new hose and clamp to the heater. Avoid any sharp bends which may kink the hose and restrict proper flow. Run Y splicer with the coolant flow. (See splicer diagram.)
3. Route power supply wire from fuse block to rocker switch, including the inline 7.5A amp fuse. And finally, ground the heater case to the chassis of the vehicle. We recommend all electrical connections are terminated or soldered and taped. (See the connection diagram below.)

## **WIRE CONNECTION DIAGRAM:**

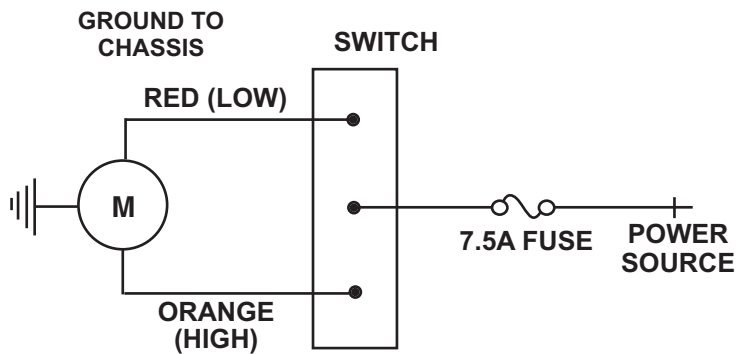

## **SPLICER DIAGRAM:**

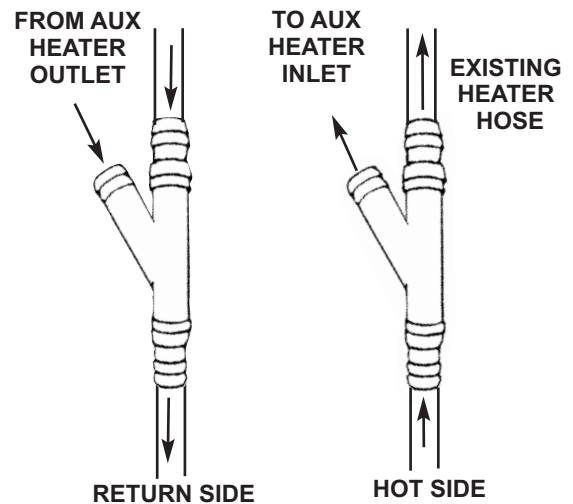

NOTE: The low speed terminal is located behind the high position due to internal switching.

## **LIMITED WARRANTY**

Northern Factory Sales warrants its Heaters to be free from all defects in manufacturing and workmanship for one year from the date of installation.

Any Heater claimed defective under this limited warranty should be forwarded to Northern Factory Sales, transportation charges prepaid, for inspection and warranty determination.

Northern Factory Sales will not be responsible for heaters damaged from misuse or neglect. Any expense associated with a warranty replacement, including but not limited to installation and transportation charges, are not covered under this warranty. This warranty provides for product replacement only. Any attempt at local repairs automatically voids this limited warranty.

Northern Factory Sales, Inc. • 1-800-328-8900  
2701 4th Avenue SW • Willmar, MN 56201